



b.o.b. Sistemi Idraulici S.p.A.

COMPANY
WITH QUALITY SYSTEM
CERTIFIED BY DNV
= ISO 9001/2000 =

2 AXLES ITRUNNER « ITR 20 »

ITR 20 B:

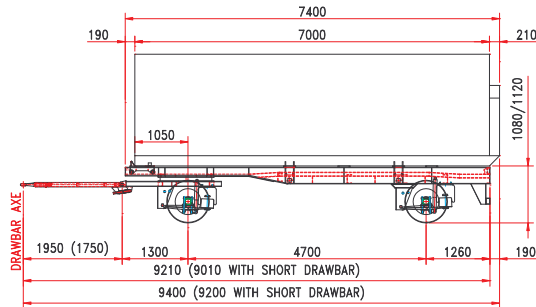

ITR 20 P:

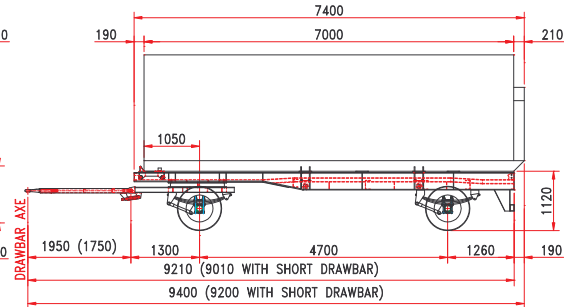

- Suitable to handle container mt 6.0+IPN/7.0+IPN
- Selfcarrying frame of BOB construction
- Suspension by leaf springs
- Braking system HALDEX with braking correction system
- No. 2 axles capacity ton 11 each
- Brake drums size mm 360X200
- Fifth wheel jost mm 1100
- Tyres No. 8+1 mod. 265/70 R. 19.5
- Spare wheel carrier with spare wheel mounted
- Container locking system with hydraulic external jaws
- Translation trolley sunk in the trailer frame made in WELDOX high tensile steel
- Mud guards in stainless steel
- Large tool box in stainless steel
- Drawbar with automatic towing eye
- Equipment sandblasted and painted red/grey chassis
- CE redaction
- Maintenance and spare parts book

Alternatively:

IT Runner with characteristics as above with pneumatic suspensions and level regulation valve

The technical details shown in this sheet are indicative and can be changed by the builder without prior notice.

B.O.B. Sistemi Idraulici S.p.A. – Regione Oltre Rea, 61 – 12060 Monchiero (CN) - Italia
P. I.V.A. 00496180043 - Tel.: +39 (0173) 780002/3 – Fax: +39 (0173) 780004
Internet: www.bobspa.com - e-mail: info@bobitalev.com