

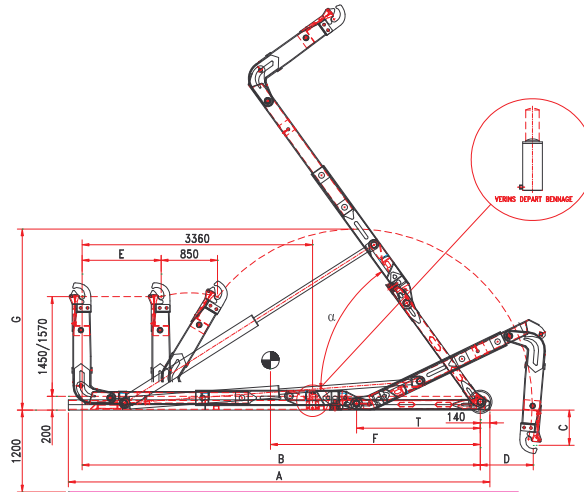

b.o.b. Sistemi Idraulici S.p.A.

COMPANY
WITH QUALITY SYSTEM
CERTIFIED BY DNV
= ISO 9001/2000 =

HOOKLIFT « BTK 20 »



MODEL	A	B	C		D	E	F	G		T	Weight kit	Tipping angle	Container min/max
			1.450	1.570				1.450	1.570				
BTK 20 C	5.950	5.600	460	570	970	1.150	3.250	2.670	2.690	1.600	2.600	57°	4.400 - 6.400
BTK 20 N	6.150	5.800	460	570	770	1.150	3.350	2.670	2.690	1.800	2.625	54°	4.600 - 6.600
BTK 20 NL	6.350	6.000	330	440	840	850	3.450	2.920	2.940	2.000	2.650	51°	4.800 - 6.800
BTK 20 L	6.550	6.200	330	440	640	850	3.550	2.920	2.940	2.200	2.675	48°	5.000 - 7.000

Lifting capacity ton. 20

Hook level mm. 1.450/1570

Telescopic and articulated arm mm. 1.150 + 850

Front / lateral oil tank

Container external hydraulic locking

Tipping Start Cylinder

Security system interlock

Painting: in chassis colour

CE Redaction with certification and operation manual and spare parts book

Kit box

Optionals:

Regenerating oil system (double speed) on hand board

Pneumatic hook security with hand board switch control

Vertical stabilizer

Rear foldable stabilizer

Extra hydraulic section with ground hand lever or with hand board control

The technical details shown in this sheet are indicative and can be changed by the builder without prior notice.

B.O.B. Sistemi Idraulici S.p.A. – Regione Oltre Rea, 61 – 12060 Monchiero (CN) - Italia
P. I.V.A. 00496180043 - Tel.: +39 (0173) 780002/3 – Fax: +39 (0173) 780004
Internet: www.bobspa.com - e-mail: info@bobitalev.com