



b.o.b. Sistemi Idraulici S.p.A.



COMPANY
WITH QUALITY SYSTEM
CERTIFIED BY DNV
=ISO 9001/2000=

2 AXLES HOOKLIFT TRAILER « 710 SL »

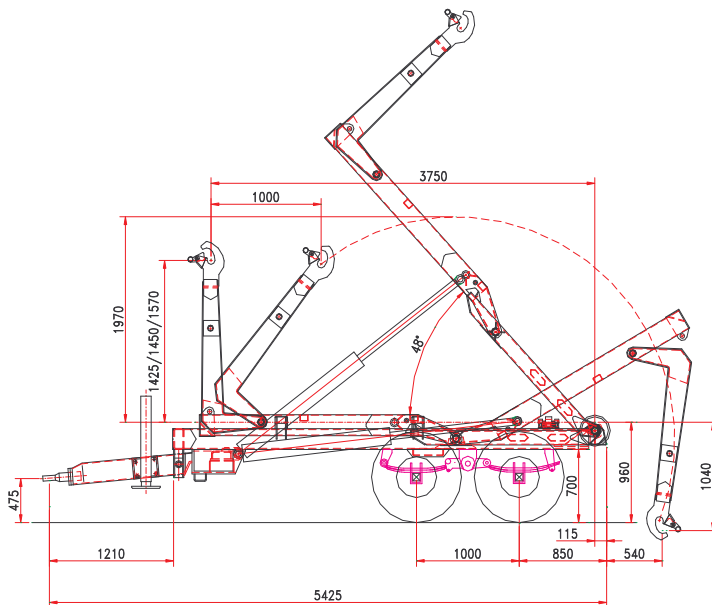

CHASSIS

| | |
|---------------------------------|------------------|
| Frame section | 200 x 100 |
| Draw bar | silent blocks |
| Leaf spring suspension (Tandem) | 12 ton |
| Axles WHB | 990 mm. |
| Axles section | 2 x 80 |
| Axles | fixed + fixed |
| Track | 1900 |
| Brake drum | 300 x 90 |
| Braking system | hydraulic |
| Towing eye | turning type |
| Draw bar support foot | mechanical |
| Wheels size | 400/60-15.5 14pr |
| Chassis loading level | 965 mm |

OLEO DYNAMIC SYSTEM

| | |
|---------------------------------|------------------|
| Tractor hydraulic | 3 controls d/act |
| Oil volume (hook lift filled) | 18 lt. |
| Cylinders oil operation demand: | |
| Tipping | 4,6 lt |
| Load / unload | 5,2 lt. |
| Tipping / loading max pressure | 180/180 bar |

ARTICULATED ARM

| | |
|----------------------------|-------------------|
| Hook level | run 1.000 mm. |
| Container external locking | 1.425/1.460/1.570 |
| Container external locking | hydraulic |
| Tipping angle | 48° |
| Tipping capacity | 8 ton |
| Lifting capacity | 8 ton |

WEIGHT AND DIMENSIONS

| | |
|-------------------------------|-----------------|
| Gross Trailer Weight (G.T.W.) | 12 ton |
| Container handling cap. | 3.000/4.600 mm. |
| Max speed | 40 Km/h |
| Tare | 2.800 kg |

OPTIONAL:

- Brake drums 300x150
- Pneumatic braking system
- Braking modular pneumatic control
- Pneumatic + hydraulic braking system
- Hydraulic support foot
- Hand pump for hydraulic support foot
- PVC half mudguards
- Additional flow control electro valve
- 3rd point hydraulic stab. cylinder
- Front hydraulic locking
- Scharmueller ball towing eye
- Toolbox

The technical details shown in this sheet are indicative and can be changed by the builder without prior notice.

B.O.B. Sistemi Idraulici S.p.A. – Regione Oltre Rea, 61 – 12060 Monchiero (CN) - Italia
P. I.V.A. 00496180043 - Tel.: +39 (0173) 780002/3 – Fax: +39 (0173) 780004
Internet: www.bobspa.com - e-mail: info@bobitalev.com