



b.o.b. Sistemi Idraulici S.p.A.



COMPANY
WITH QUALITY SYSTEM
CERTIFIED BY DNV
= ISO 9001/2000 =

2 AXLES HOOKLIFT TRAILER « 1014 SL »

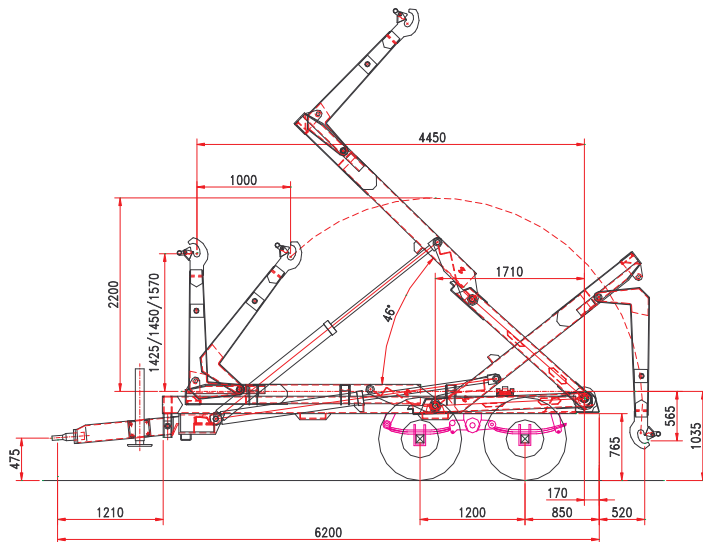

CHASSIS

Frame section	200 x 100
Draw bar	silent blocks
Leaf spring suspension (Tandem)	16 ton
Axles WHB	1.200 mm.
Axles section	2 x 100
Axles	fixed + fixed
Track	1900
Brake drum	300 x 90
Braking system	hydraulic
Towing eye	turning type
Draw bar support foot	mechanical
Wheels size	500/50-17 14pr
Chassis loading level	1.030 mm

WEIGHT AND DIMENSIONS

Gross Trailer Weight (G.T.W.)	16 ton
Container handling cap.	3.500/5.500 mm.
Max speed	40 Km/h
Tare	3.500 kg

OLEO DYNAMIC SYSTEM

Tractor hydraulic	3 controls d/acting
Oil volume (hook lift filled)	30 lt.
Cylinders oil operation demand:	
Tipping	6,8 lt
Load / unload	7,4 lt.
Tipping / loading max pressure	160/180 bar

ARTICULATED ARM

run	1.000 mm.
Hook level	1.430/1.460/1.570
Container external locking	hydraulic
Tipping angle	46°
Tipping capacity	12 ton
Lifting capacity	12 ton

OPTIONAL:

Steering Axle
Brake drums 300x150
Pneumatic braking system
Brakes modular pneumatic control
Pneumatic + hydraulic braking system
Hydraulic support foot
Hand pump for hydraulic support foot
PVC half mudguards
Additional flow control electro valve
3rd point hydraulic stab. cylinder
Hydraulic draw bar
Front hydraulic locking
Scharmueller ball towing eye
Toolbox

The technical details shown in this sheet are indicative and can be changed by the builder without prior notice.

B.O.B. Sistemi Idraulici S.p.A. – Regione Oltre Rea, 61 – 12060 Monchiero (CN) - Italia
P. I.V.A. 00496180043 - Tel.: +39 (0173) 780002/3 – Fax: +39 (0173) 780004
Internet: www.bobspa.com - e-mail: info@bobitalev.com