



b.o.b. Sistemi Idraulici S.p.A.



COMPANY  
WITH QUALITY SYSTEM  
CERTIFIED BY DNV  
= ISO 9001/2000 =

## 2 AXLES HOOKLIFT TRAILER « 1419 SL »

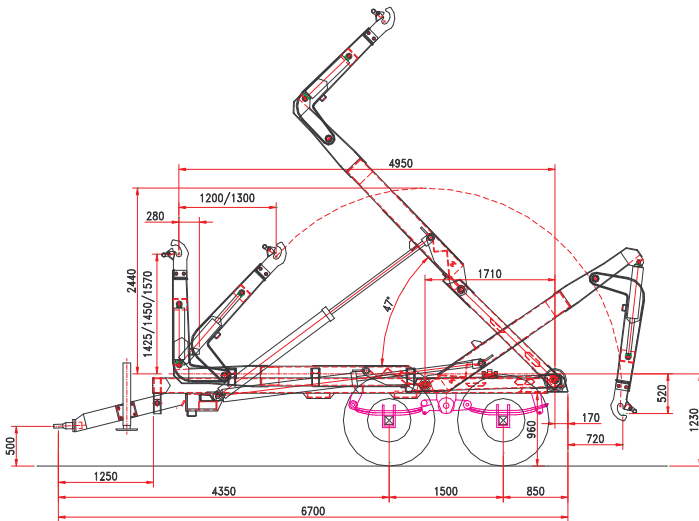

### **CHASSIS**

Frame section	200 x 100
Draw bar	silent block
Leaf spring suspension (Tandem)	21 ton
Axles WHB	1.500 mm.
Axles section	2 x 110
Axles	fixed + fixed
Track	2000
Brake drum	400 x 80
Braking system	hydraulic
Towing eye	turning type
Draw bar support foot	mechanical
Wheels size	500/60-22,5 16pr
Chassis loading level	1.090 mm

### **WEIGHT AND DIMENSIONS**

Gross Trailer Weight (G.T.W.)	21 ton
Container handling cap.	4.000/6.000 mm.
Max speed	40 Km/h
Tare	4.500 kg

### **OLEO DYNAMIC SYSTEM**

Tractor hydraulic	3 controls d/action
Oil volume (hook lift filled)	45 lt.
Cylinders oil operation demand:	
Tipping	8 lt
Load / unload	9,3 lt.
Tipping / loading max pressure	180/200 bar

### **ARTICULATED ARM**

run	1.200 mm.
Hook level	1.430/1.460/1.570
Container external locking	hydraulic
Tipping angle	47°
Tipping capacity	16 ton
Lifting capacity	16 ton

### **OPTIONAL:**

Steering Axle  
Axles hydraulic steering  
Brake drums 406x120  
Brakes BPW 410x120  
Pneumatic braking system  
Hydraulic draw bar  
Braking modular pneumatic control  
Pneumatic + hydraulic braking system  
Hydraulic support foot  
Hand pump for hydraulic support foot  
PVC half mudguards  
Additional flow control electro valve  
3rd point hydraulic stab. cylinder  
Scharmueller ball towing eye  
Toolbox

The technical details shown in this sheet are indicative and can be changed by the builder without prior notice.

**B.O.B. Sistemi Idraulici S.p.A.** – Regione Oltre Rea, 61 – 12060 Monchiero (CN) - Italia  
P. I.V.A. 00496180043 - Tel.: +39 (0173) 780002/3 – Fax: +39 (0173) 780004  
Internet: [www.bobspa.com](http://www.bobspa.com) - e-mail: [info@bobitalev.com](mailto:info@bobitalev.com)