



b.o.b. Sistemi Idraulici S.p.A.



COMPANY  
WITH QUALITY SYSTEM  
CERTIFIED BY DNV  
= ISO 9001/2000 =

## 2 AXLES HOOKLIFT TRAILER « 1824 SL »

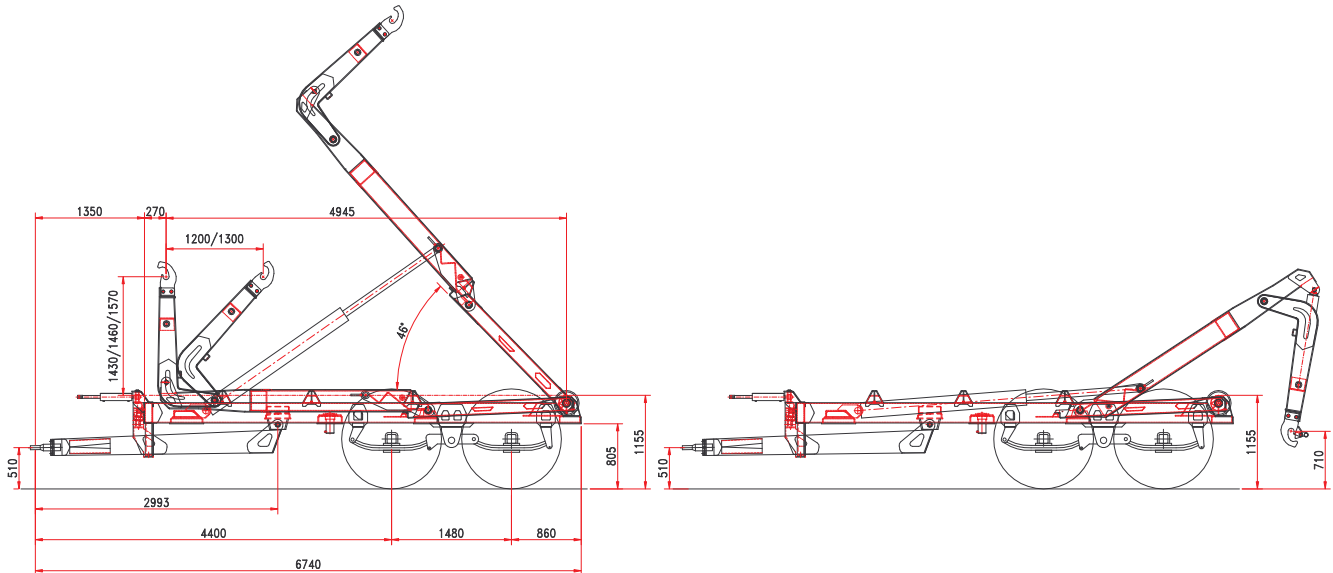

### **CHASSIS**

Frame section	250 x 100
Draw bar	silent blocks
Leaf spring suspension (Tandem)	24 ton
Axles WHB	1.500 mm
Axles section	2 x 110
Axles	fixed + fixed
Track	2000 mm
Brake drum	406 x 120
Braking system	hydraulic
Towing eye	turning type
Draw bar support foot	hydraulic
Wheels size	500/60-22,5 16pr
Chassis loading level	1.200 mm
3 <sup>rd</sup> point hydraulic stab. cylinder	standard

### **OLEO DYNAMIC SYSTEM**

Tractor hydraulic	3 controls d/acting
Oil volume (hook lift filled)	46 lt.
Cylinders oil operation demand:	
Tipping	11,4 lt
Load / unload	12,7 lt.
Tipping / loading max pressure	180/200 bar
4 elements electro valves	standard

### **ARTICULATED ARM**

Hook level	run 1.200 mm.
Container external locking	1.430/1.460/1.570
Tipping angle	hydraulic
47°	
Hoist start cylinder	standard
Tipping capacity	18 ton
Lifting capacity	18 ton

### **WEIGHT AND DIMENSIONS**

Gross Trailer Weight (G.T.W.)	23 ton
Tare	5.300 kg
Container handling cap.	4.000/6.000 mm.
Max speed	40 Km/h

### **OPTIONAL:**

Steering Axle
Axles hydraulic steering
Brakes BPW 410x120
Pneumatic braking system
Hydraulic draw bar
Braking modular pneumatic control
Pneumatic + hydraulic braking system
Hydraulic support foot
Hand pump for hydraulic support foot
PVC half mudguards
Scharmueller ball towing eye
Toolbox

The technical details shown in this sheet are indicative and can be changed by the builder without prior notice.