



b.o.b. Sistemi Idraulici S.p.A.



COMPANY  
WITH QUALITY SYSTEM  
CERTIFIED BY DNV  
= ISO 9001/2000 =

### 3 AXLES HOOKLIFT TRAILER « R 30 ITS»

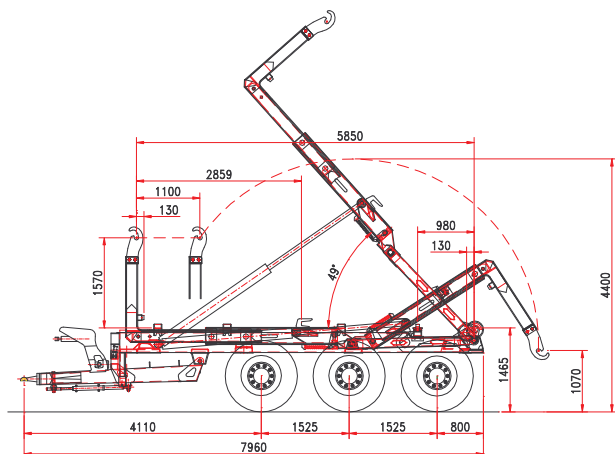

#### **CHASSIS**

Frame section	300 x 100
suspensions	hydraulic/leaf springs
Axles WHB	1.500/1.800 mm
Axles section	3x150
Industrial axles	track 2.150 mm
Axles	steering+fixed+steering
Brake drum	420 x 180
Braking system	hydraulic
Draw bar	hydraulic
Towing eye	ball type Scharmueller
Draw bar support feet	2 x hydraulic
Chassis loading level	1.300 mm

#### **OLEODYNAMIC SYSTEM**

Tractor hydraulic	1 controls d/act
Piston pump	100 lt
RPM	1.000
Oil tank	120 l
Pump max. pressure	350 bar
Radio control	standard

#### **TELESCOPIC ARM**

run	1.300
Hook level	1.430/1.460/1.570
Container external locking	hydraulic
Tipping angle	45°
Tipping capacity	30 ton
Lifting capacity (according to hook level)	30 ton

#### **TRAILER WEIGHT AND DIMENSIONS**

Gross Trailer Weight (G.T.W.)	33 ton
Tare (indicative)	9.500 kg
Container handling cap.	6.000/7.500 mm.
Max speed	60 km/h

#### **OPTIONALS**

Articulated arm (+ telescopic standard) (on request)  
Steering axle BPW  
Axle hydraulic steering with draw bar equalizer  
Axle hydraulic steering BPW with draw bar equaliz.  
Hydraulic suspensions  
Hydraulic draw bar  
Pneumatic braking system  
Hydraulic-pneumatic braking system  
Braking system modular type  
Modular pneumatic braking system for hydr. susp.  
Axle sections 420x180  
Section 150 mm x track 2.150  
Towing hook Rockinger with electric and ABS  
braking connection  
Additional hooklift flow control element  
Container front hydraulic locking  
Regenerating oil system (double speed)  
Automatic greasing system electropneumatic

The technical details shown in this sheet are indicative and can be changed by the builder without prior notice.